

**Cabinet Type**      **Full Height Glass Door**

**Model Designation**      **FD9**

**File Reference**      1151

<b>Document Issue</b>	1	27.07.10	GR	Provisional Tech Data Sheet
	2	17.05.11	IRG	Commissioning Data Added
	3	25.05.11	AG	Electrical Exclusion Zone added to View
	4	18.08.11	GR	Services Plans Updated
	5	24.01.12	NM	Refrigerant Charge, THR & Flow Rates Updated

cabinet **TECHNICAL DATA**

## Cabinet Technical Data Sheet – FD9

Product Type	Frozen Food 3L1
Product Temperature	-18°C / -22°C
Maximum Design Ambient	25°C 60%RH

Case Length [m]	4DR	3DR	2DR
-----------------	-----	-----	-----

### Refrigeration Data

Nett Environmental Cooling Effect	-0.19	-0.34	-0.09
Refrigerant Charge per System R1270	600g	550g	600g

Electrical Data (individual loads 230v)	Watts	Amps	Watts	Amps	Watts	Amps
Defrost Heaters	3800	16.5	2750	11.9	1700	7.4
Fans	28	0.12	21	0.09	14	0.06
Trim Heaters	1050	4.57	680	2.96	550	2.39
Controller	10	0.04	10	0.04	10	0.04
Lights	390	0.76	140	0.61	105	0.46
Condensing unit	2568	11.2	1551	6.8	1284	5.58

Electrical Data (@400V 3ph 50Hz)	L1	L2	L3	L1	L2	L3	L1	L2	L3
Maximum Load – Electric Defrost	5.9	8.25	8.25	3.7	5.95	5.95	2.95	3.7	3.7

### Miscellaneous Data

Total Heat Rejection THR [KW]	5.01	3.63	2.51
THR (Water only) [KW]	4.21	2.83	2.11
Glycol Flow Rate [Kg/S]**	0.1823	0.1226	0.0912
Water inlet temperature		18°C	
Water outlet temperature		24°C	
Plate Heat Exchanger [Kpa] each	2 @ 0.86Kpa	1 @ 2.4Kpa	1 @ 0.86Kpa
Drain Outlet		32mm Plastic	
Electrical Connections		Underside of Cabinet LHS	
Chilled Water Connections	22mm	28mm	22mm

Set-Up Data**	Frozen	Ice Cream
Cut in Temperature [°C]	-22	-24
Differential [K]	2	2
Cabinet Temperature Ratio (%)	50	50
Anti Cycle Time [Seconds]	180	180
Lag Comp Delay [Seconds]	60	60
N° Defrosts (per 24hrs)	2	2
Maximum Defrost Time [mins]	45	45
Defrost Termination Temp [°C]	1	1
Drain Down Time [mins]	2	2
Fans in Defrost	Off	Off
Integral Control	Basic	Basic
Trim Heater Control (%)	60	60

NOTES! \* 12/12 Trading Conditions

\*\* Set-up data is for guidance only. Final settings to be determined by commissioning contractor.

\*\*\* Flow rate for Glycol based on 30% @ 20°C from ASHRAE = 3.848 KJ/(KG-K)

Section Drawing – FD9

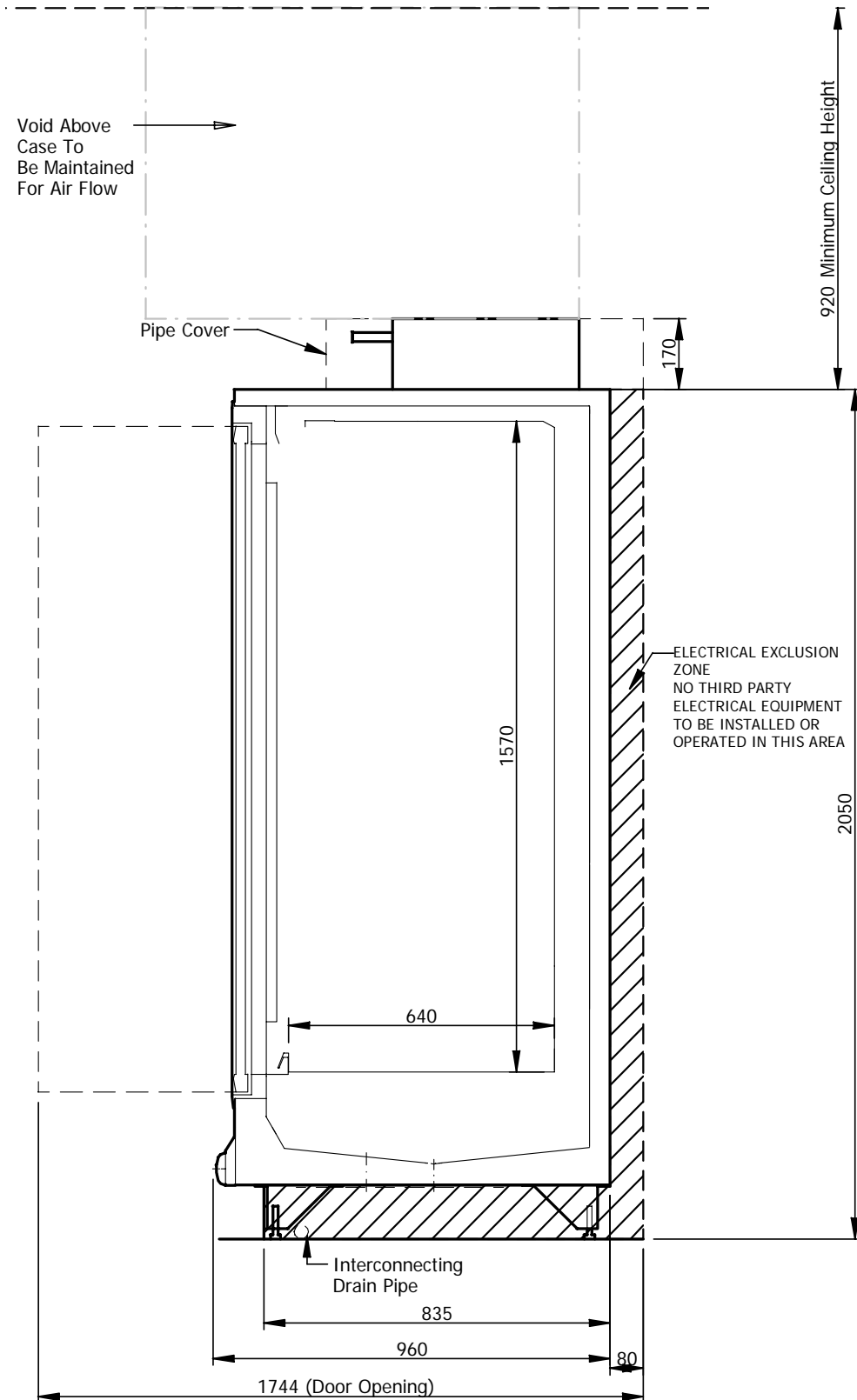

Ref:- DS1151-02

Plan Drawing – FD9

- KEY
- Feet Positions
  - Refriger. Outlet
  - ◐ Drain Outlet
  - ⊗ Elect. Outlet
  - ⊕ Mains Supply

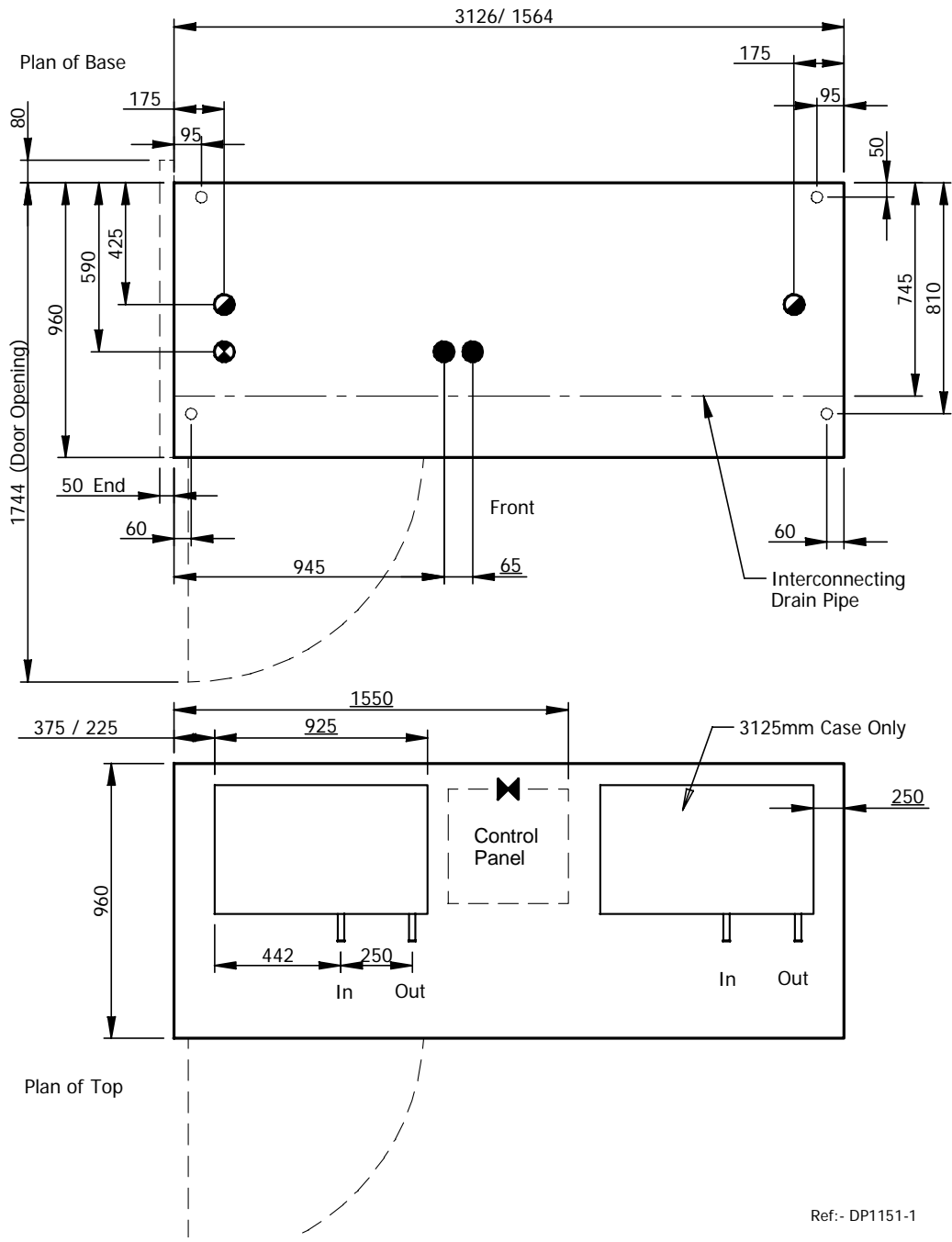

Ref:- DP1151-1

**Plan Drawing – FD9 (Twin Condenser Box)**

- KEY
- Feet Positions
  - Refrig. Outlet
  - ◐ Drain Outlet
  - ⊗ Elect. Outlet
  - ⊗ Mains Supply

